

# همکاران سیستم

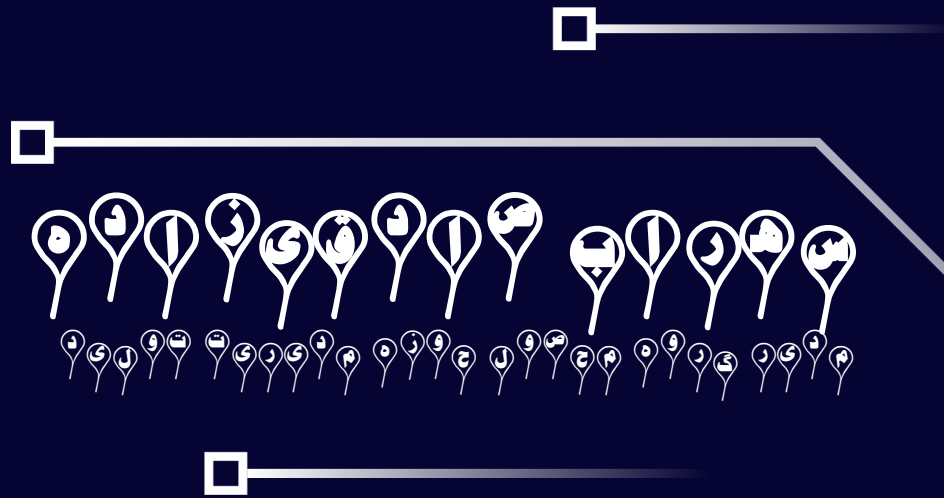







compound annual growth rate  
(CAGR) of ۱۱.۱۱%

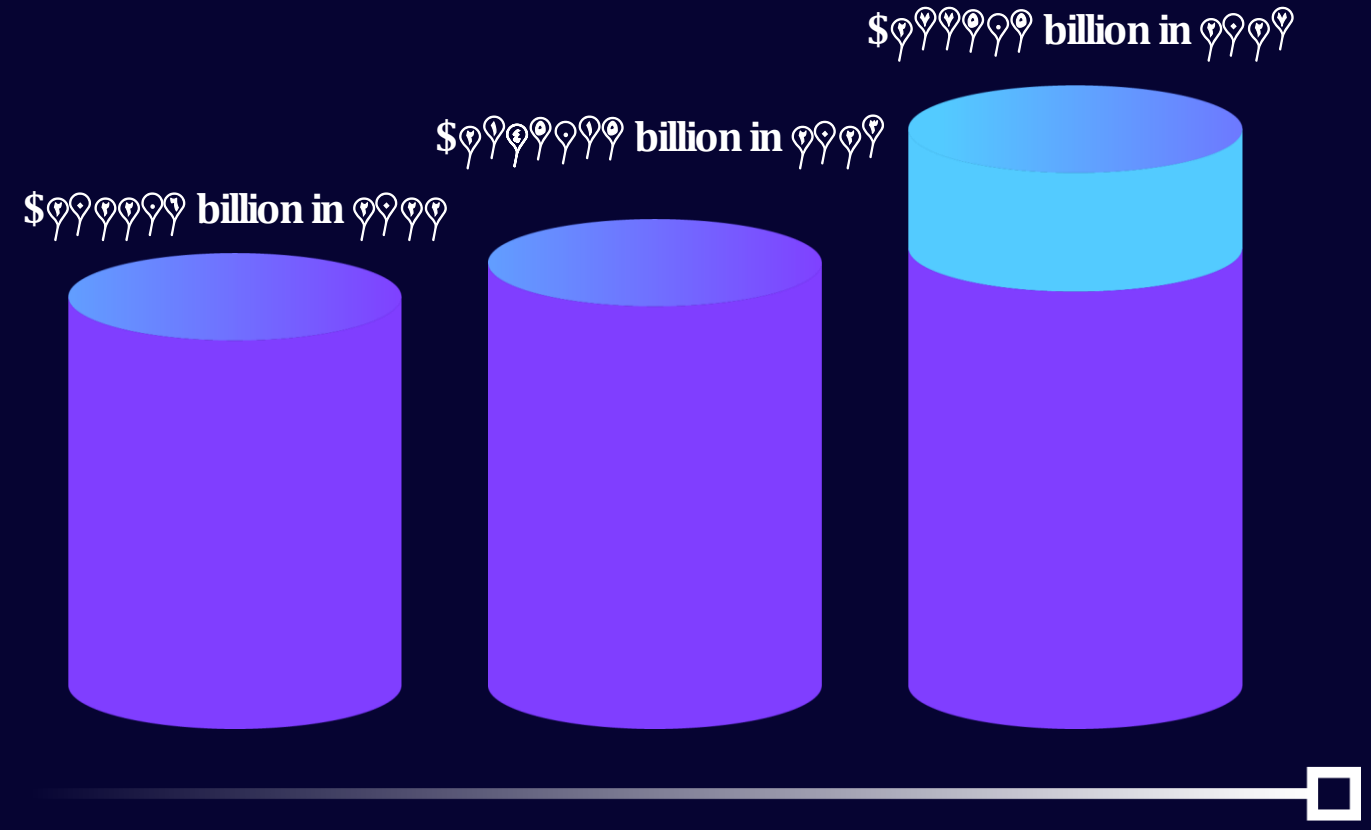

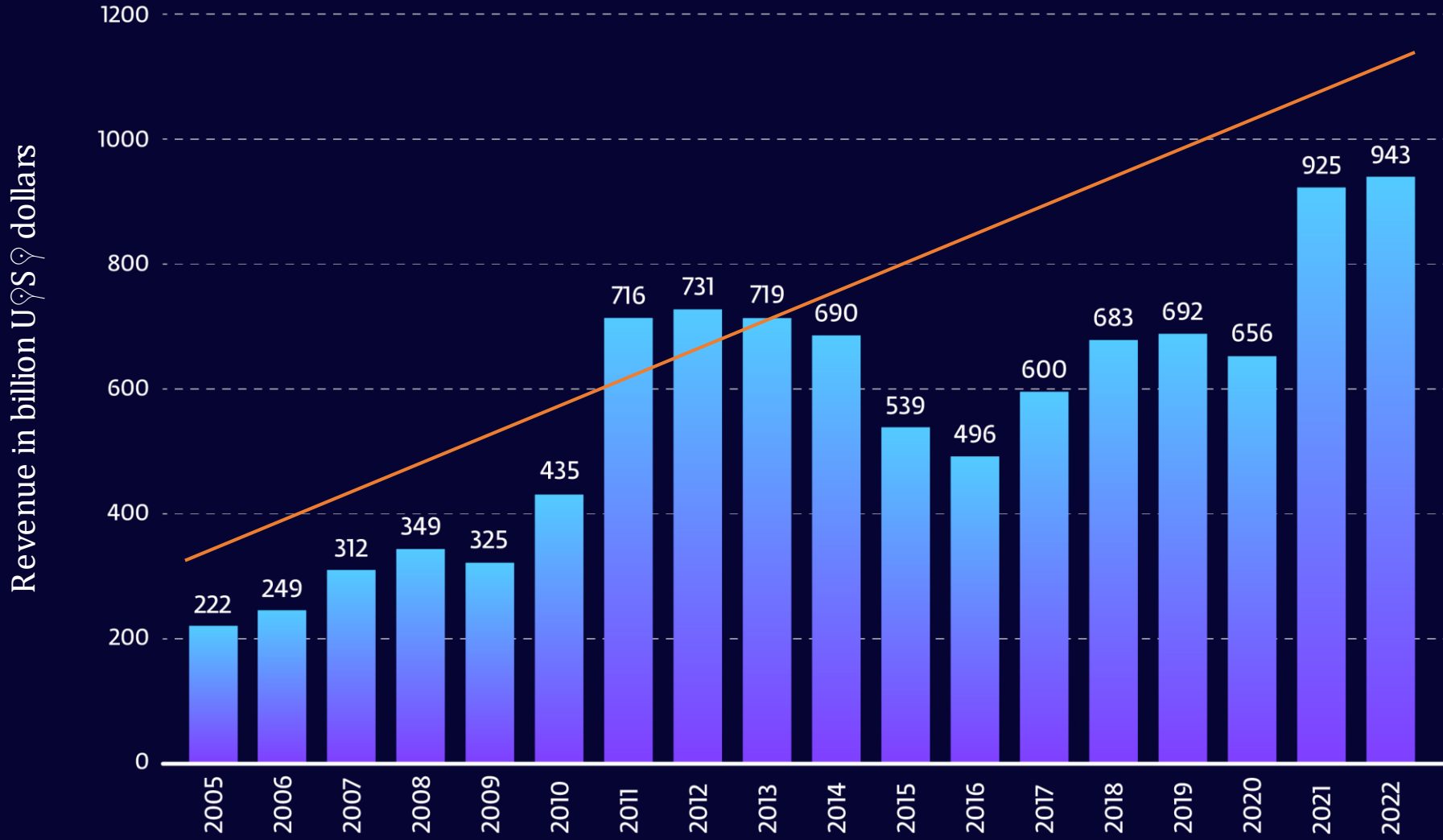

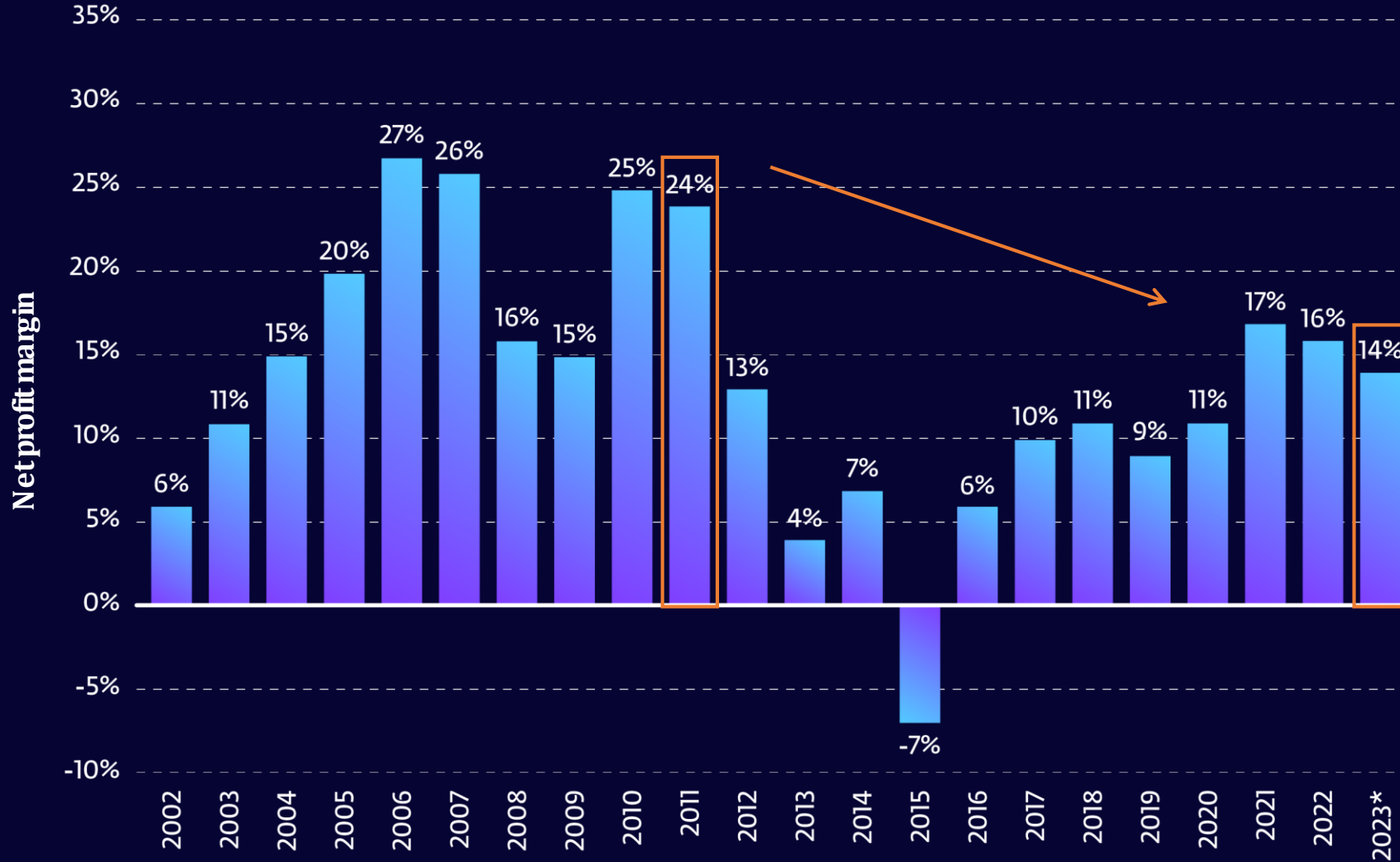

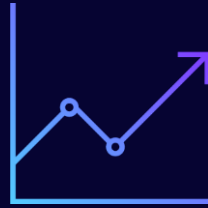

**UNPLANNED DOWNTIME**

Hydraulic power and belt drive failures cause up to

**47% OF DOWNTIME**

at mining operations

**\$180,000 IN LOST PRODUCTION**

per incident



مدیریت  
لاستیک‌ها



کنترل  
هزینه‌های  
تعمیرات



مانیتورینگ  
و پایش  
لحظه‌ای

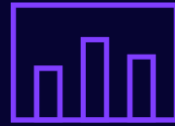

استفاده  
موثر  
از داده‌ها

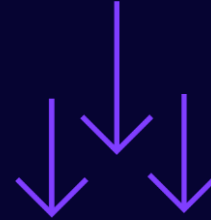

کاهش  
توقفات

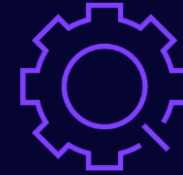

عدم یکپارچگی  
سیستم‌های  
تعمیراتی با  
سایر سیستم‌ها

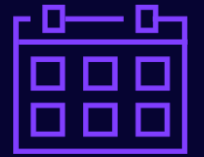

برنامه‌ریزی  
منظم  
فعالیت‌های PM





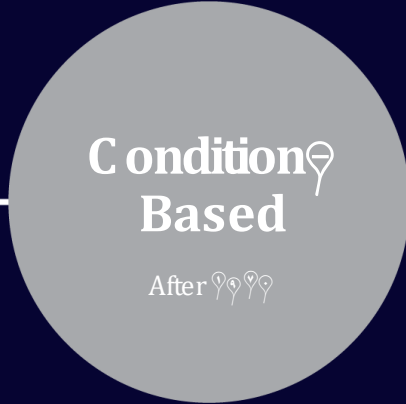
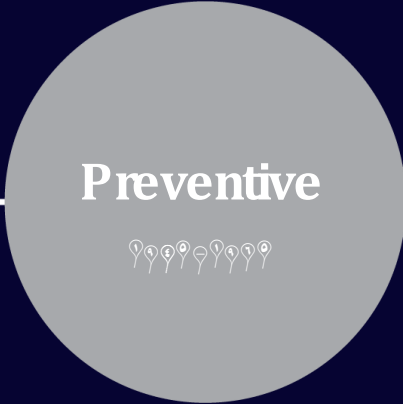

Fix it when it breaks

📍📍 Recommended

- ✓ به داده‌های آسان
- ✓ بدون نیاز به تجهیزات
- ✓ انعام با حداقل انرژي و زمان

- وقوع اتفاقات نادر و استه
- تحلیل‌های ایمنی و زیست محیطی
- کاهش عمده تجهیزات
- افزایش ایمنی و کاهش
- هزینه‌های بالای تعمیرات

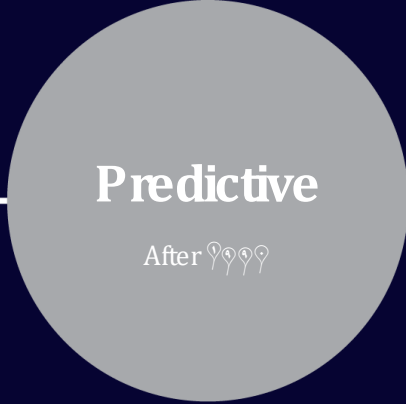

Fix it Before it breaks



- ✓ نیکی‌ها در تدارکات‌های زودرس سطح عملیاتی
- ✓ کالاهای ترفیحات در زمان‌های ناهماهنگ
- ✓ تدارکات‌های زودرس در تدارکات‌های زودرس
- ✓ تدارکات‌های زودرس در تدارکات‌های زودرس
- در نظر گرفتن زمان‌های تدارکات‌های زودرس
- نیکی‌ها در تدارکات‌های زودرس
- تدارکات‌های زودرس در تدارکات‌های زودرس
- تدارکات‌های زودرس در تدارکات‌های زودرس

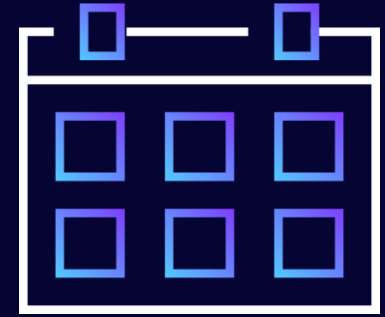

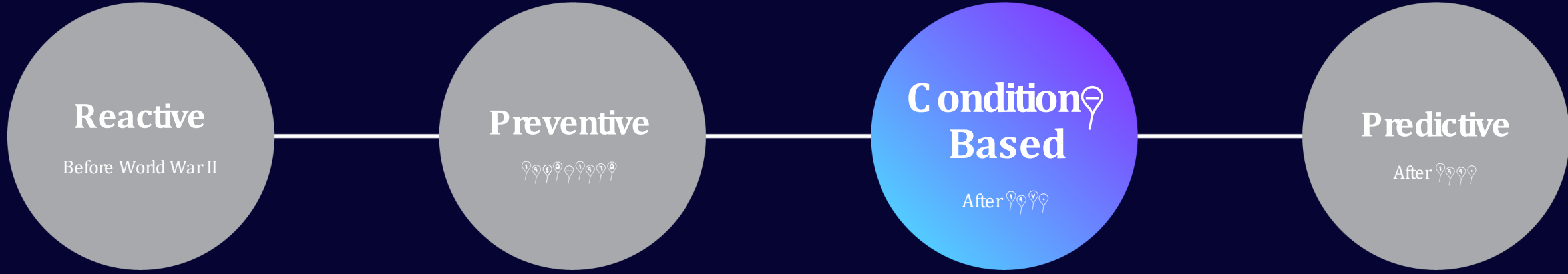

If It Is not Broke ☹️ don't fix It

- ✓ یاهو هش هزی نه ههای تا عمی رات
- ✓ کاهش م ع رف قطعات
- ✓ یاهش تا وقت ات
- ✓ ای لاهی از و سعی تا واقعی تا عمی ز

- نی از م نه ا ب ز ا ر و م کی انی ز م ههای بی ضرر ت ه
- نی از م نه ا ب ز ا ر د ن سطح آم و ز شی



Vehicle orientation, dynamics & terrain mapping

Environment monitoring & operator comfort

Gearbox health

Wireless data aggregator with  
vehicle bus connection

Pumps, motors  
& cylinders

Structural loads

Engine monitoring

Drivetrain torque

Suspension loads  
and dynamics

Tire pressure & temp

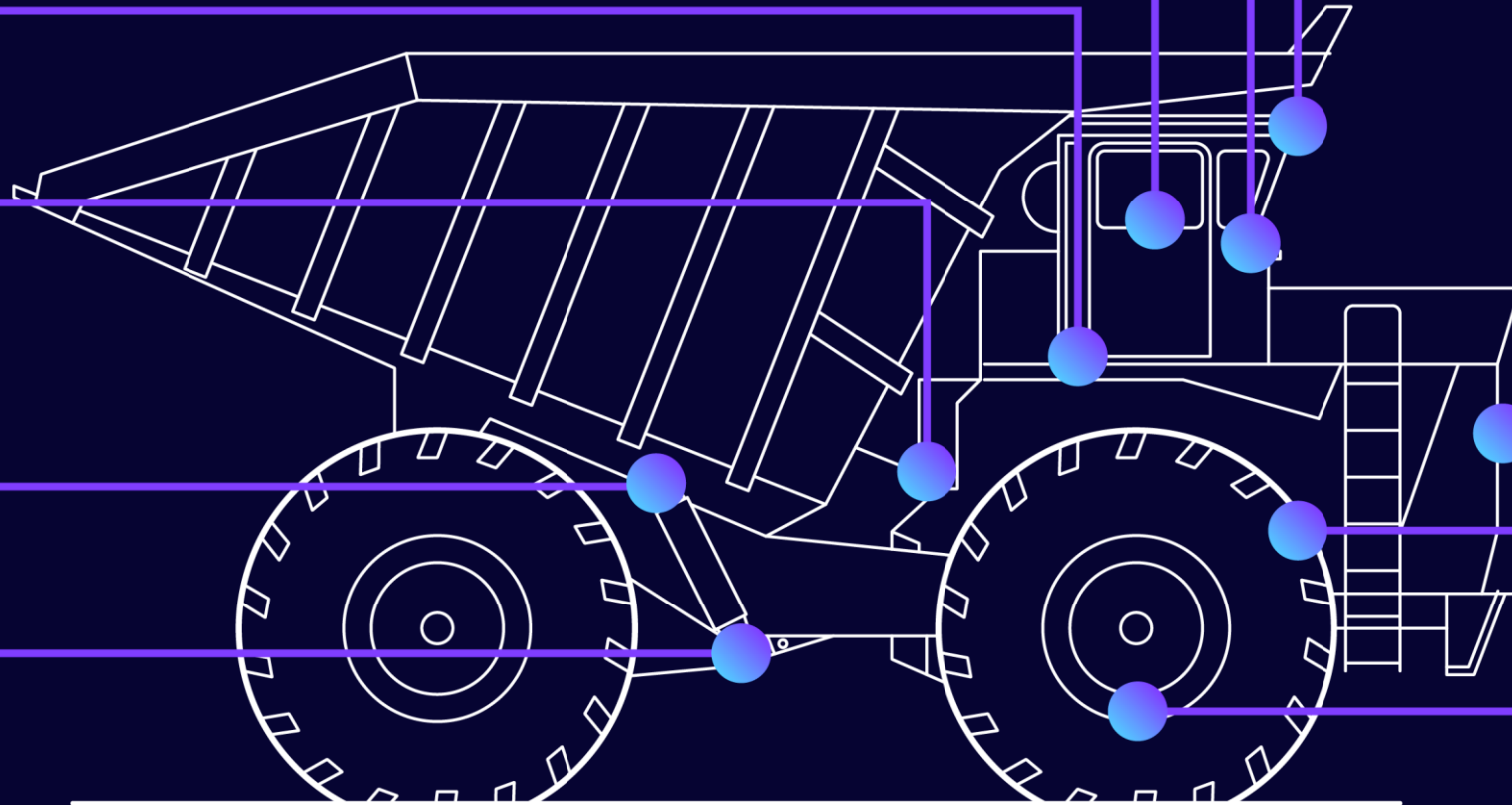

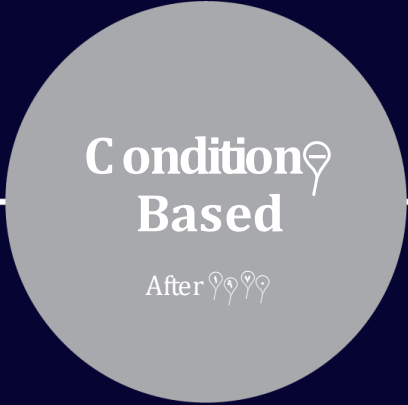

If It Is not Broke📍 don't fix It

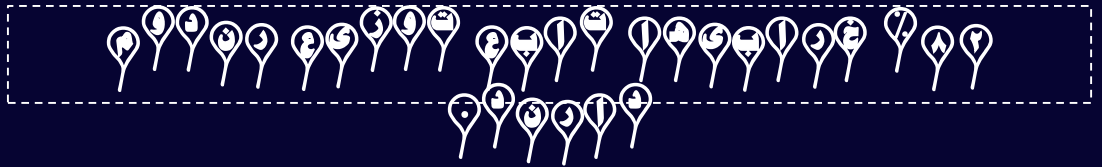
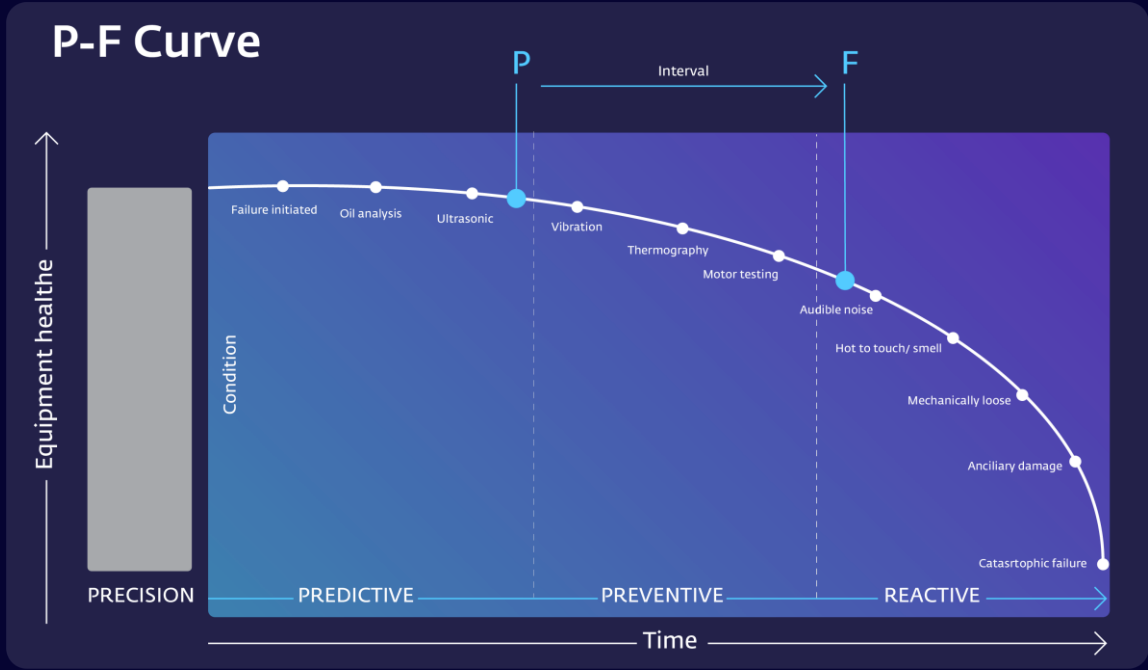

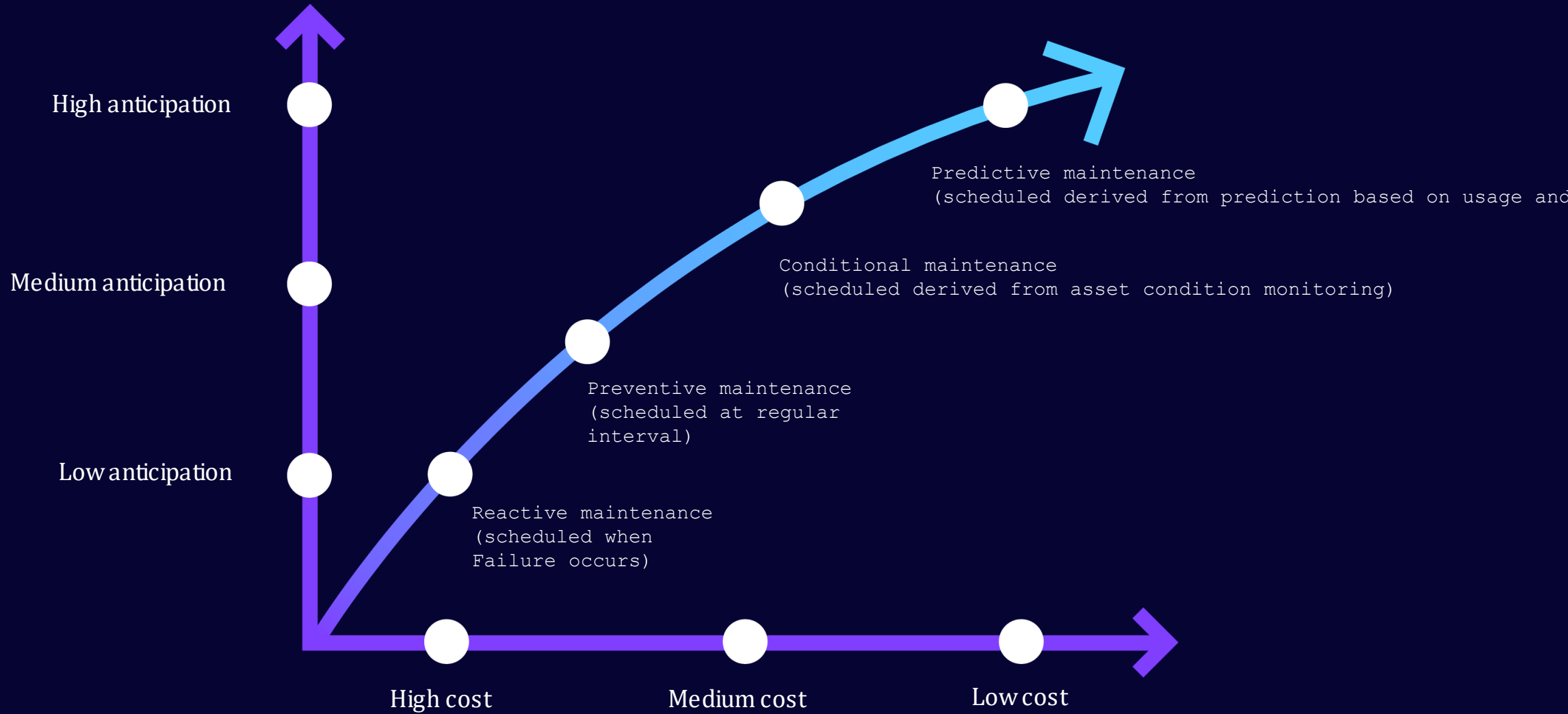



 YOUR LOGO GOES HERE

**Organisation:** Template Library  
**Project:** Example Template Project  
**Team:** Example Team

**Template ID:** DP-PEA-0005  
**Template Version:** 2 Form Version: 1.6  
**Form created:** Wednesday, 03 April 2019, 9:46:15 am

---

## Maintenance Request Form

**Automated Form Number**  Template Library-Example Template Project-Example Team-DP-PEA-0005-0

**Date of Request** Wednesday, 03 April 2019

**Building or Location** Site 3B

**Person Making Request** Dave Hodgson

**Requestors Contact Details** +61 456 123 456

**Priority** Needs to be done ASAP

**Maintenance Request/s**

Details of Repair	Where is Repair Located?	When and How Did this Occur?
Floor panel cracked and had to be pulled up entirely	Bathroom area	There has been some movement in the floor there for a while, but it gave way when I was walking on it today
Cracking in outer house casing which is leading to water leaks and floor issues	East side of building	Not sure. We just noticed the leak and then went to investigate where it was coming from.

**Photo or video**  
  
 See full page photos attached at end of PDF

**Additional comments from requestor**  
 We had requested that the floor panels be replaced already, so please get this solved ASAP so that work can continue.

**Access**  
 Use of keys are permitted to enter property

**Signature of Requestor**  
 Dave Hodgson, Wednesday, 03 April 2019, 9:53:57 am

---

## Maintenance Check or Repair

**Section to be completed by the maintenance department or responsible person**

**Outcome of Maintenance Visit**  
 Inspected and will come back for repairs

**Comments from maintenance request visit**  
 I have inspected the problems and they both need to be replaced.  
 I have ordered parts which will be coming within 2 business days and will be coming back to repair as soon as we have the materials.  
 I have also flagged with the quality team to check for water damage in the floors by the end of the week to make sure nothing else is damaged.

**Photo and video**  
 See full page photos attached at end of PDF

**Signature of Maintenance Worker**  
 Sophie Turner, Wednesday, 03 April 2019, 9:56:22 am

---

Generated with [gashryot.com](http://gashryot.com) Printed version is uncontrolled Page 1 of 3 This PDF was created at Wednesday, 03 April 2019, 9:59:50 am



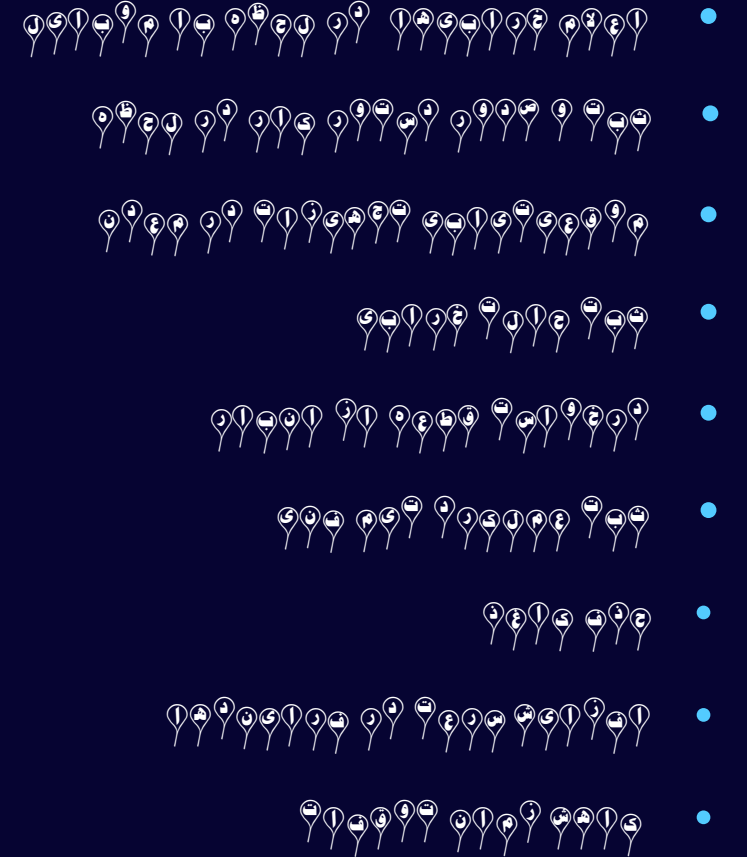
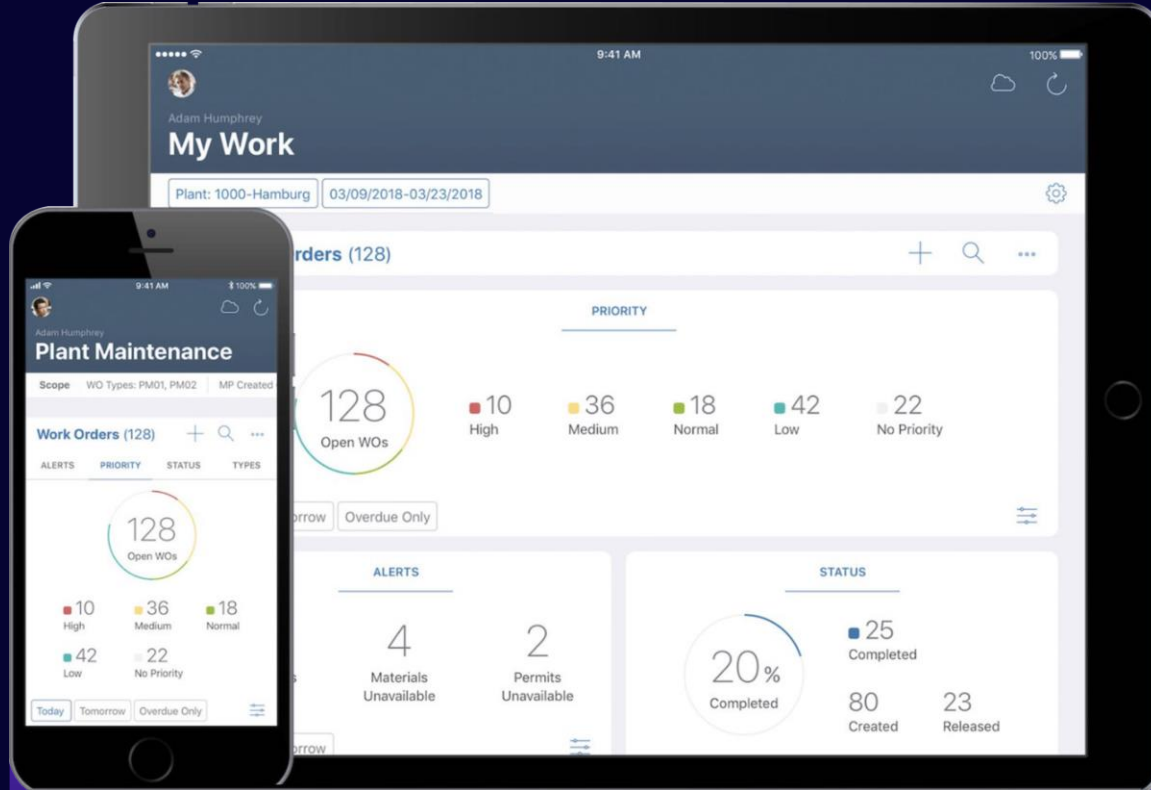





نوع توقف دستور کارها

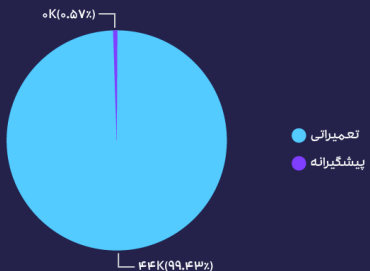

رشد تعداد توقفات در طول زمان

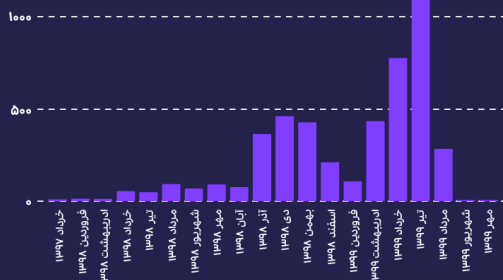

نسبت زمانی دستور کارها

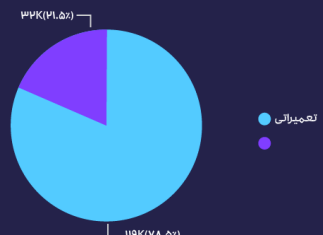

مدت زمان انجام دستور کار مراکز کاری

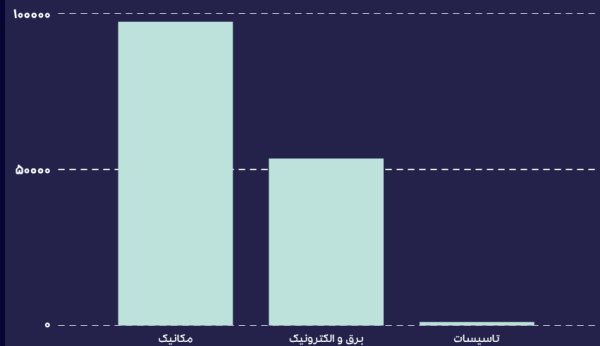

سهم هر یک از مراکز کاری مجری از نفر - ساعت پیشگیرانه



سهم هر یک از مراکز کاری مجری از نفر - ساعت تعمیراتی



نمودار پارتو مدت زمان توقف

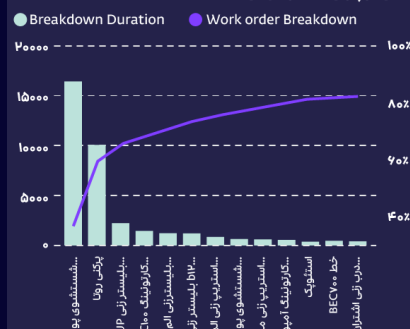

رشد مدت زمان توقفات در طول زمان

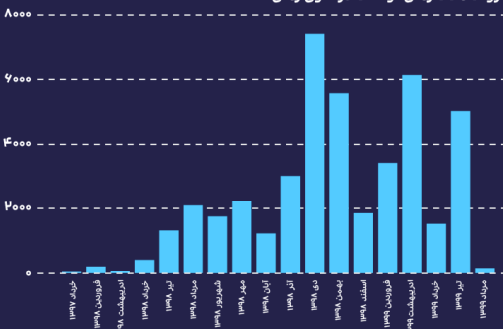

نسبت تعدادی دستور کارها

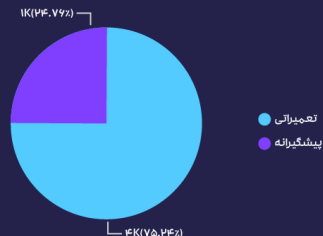

تعداد دستور کار مراکز کاری

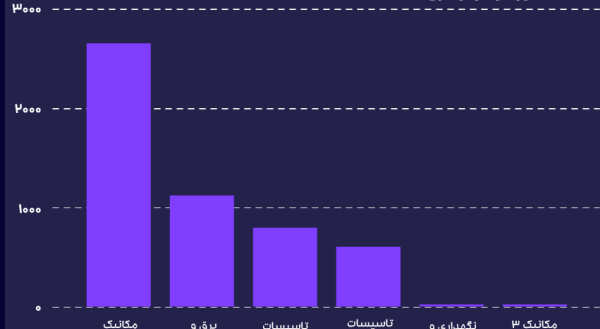

سهم هر یک از مراکز کاری از تعداد دستور کارهای پیشگیرانه



سهم هر یک از مراکز کاری از تعداد دستور کارهای تعمیراتی

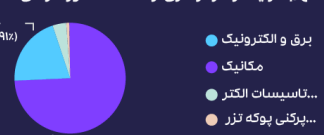



## Maintenance intervals

500-hour maintenance	1,000-hour maintenance	2,000-hour maintenance	6,000-hour maintenance
<ul style="list-style-type: none"> <li>• Engine air filter assembly</li> <li>• Transmission oil filter</li> <li>• Engine oil filter</li> <li>• Fuel pre-filter</li> <li>• AC fresh air filter</li> <li>• AC recirc air filter</li> <li>• Fuel main filter</li> <li>• KOWA</li> <li>• Engine oil</li> </ul>	<ul style="list-style-type: none"> <li>• Engine air filter assembly</li> <li>• Transmission oil filter</li> <li>• Engine oil filter</li> <li>• Fuel pre-filter</li> <li>• AC fresh air filter</li> <li>• AC recirc air filter</li> <li>• Fuel main filter</li> <li>• KOWA</li> <li>• Engine oil</li> <li>• O-ring (transmission oil strainer)</li> <li>• O-ring (transmission oil strainer)</li> <li>• Transmission oil</li> </ul>	<ul style="list-style-type: none"> <li>• Engine air filter assembly</li> <li>• Transmission oil filter</li> <li>• Engine oil filter</li> <li>• Fuel pre-filter</li> <li>• AC fresh air filter</li> <li>• AC recirc air filter</li> <li>• Fuel main filter</li> <li>• KOWA</li> <li>• Engine oil</li> <li>• O-rings</li> <li>• Transmission oil</li> <li>• Hydraulic oil filter</li> <li>• Hydraulic tank breather</li> <li>• Diesel exhaust fluid (DEF) pump filter</li> <li>• DEF tank breather</li> <li>• KCCV filter</li> <li>• Axle oil (each)</li> <li>• Hydraulic oil</li> </ul>	<ul style="list-style-type: none"> <li>• Engine air filter assembly</li> <li>• Transmission oil filter</li> <li>• Engine oil filter</li> <li>• Fuel pre-filter</li> <li>• AC fresh air filter</li> <li>• AC recirc air filter</li> <li>• Fuel main filter</li> <li>• KOWA</li> <li>• Engine oil</li> <li>• O-rings</li> <li>• Transmission oil</li> <li>• Hydraulic oil filter</li> <li>• Hydraulic tank breather</li> <li>• Diesel exhaust fluid (DEF) pump filter</li> <li>• DEF tank breather</li> <li>• KCCV filter</li> <li>• Axle oil (each)</li> <li>• Hydraulic oil</li> <li>• Coolant</li> </ul>





## Equipment Service Overlap

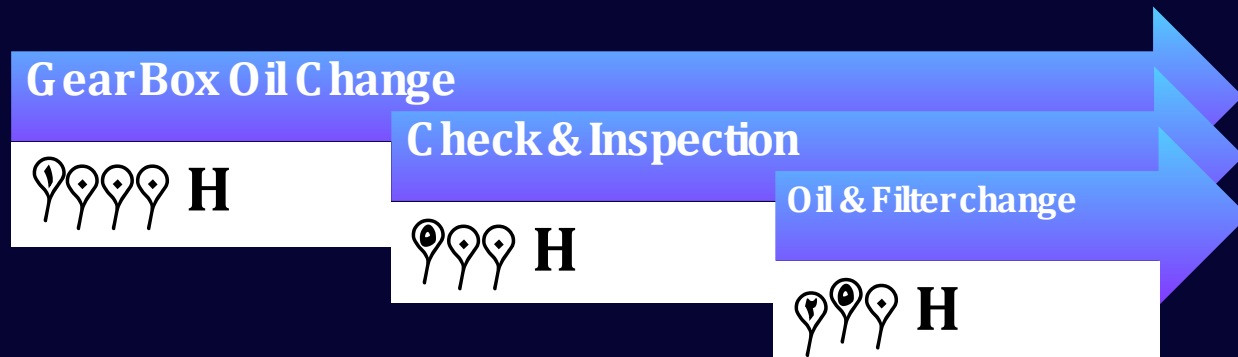



# پدیده های نوظهور در سازمان

- پدیده های نوظهور در سازمان

- همکاران سیستم





- همکاران سیستم

- همکاران سیستم

- همکاران سیستم





- 
- 
- 
- 
- 
- 

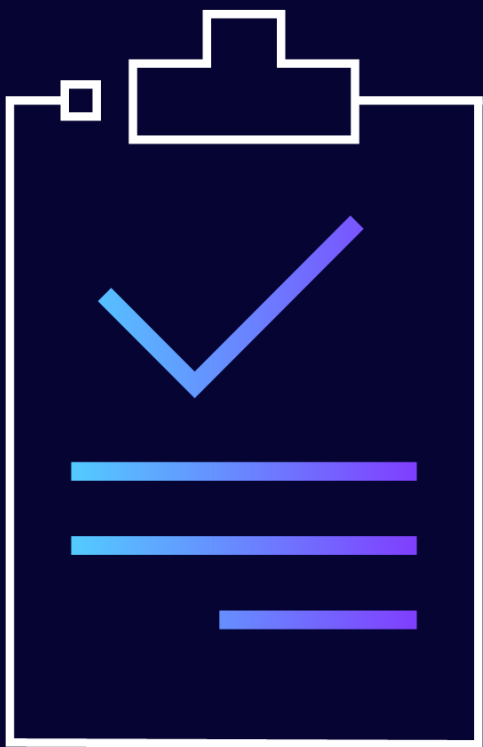

- مدیریت امور مالی و اداری
- خدمات مشتریان و پشتیبانی
- مدیریت منابع انسانی
- مدیریت بازاریابی و فروش
- خدمات فنی و تعمیرات

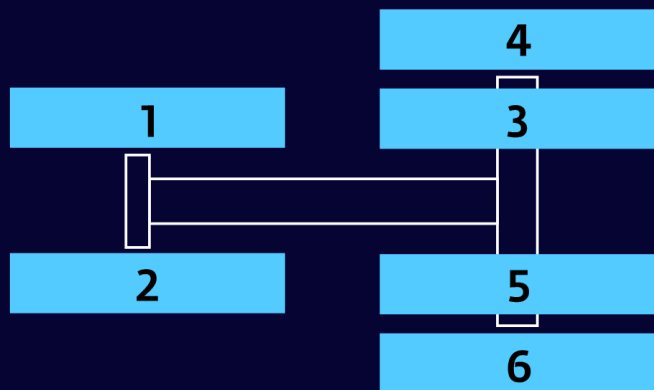
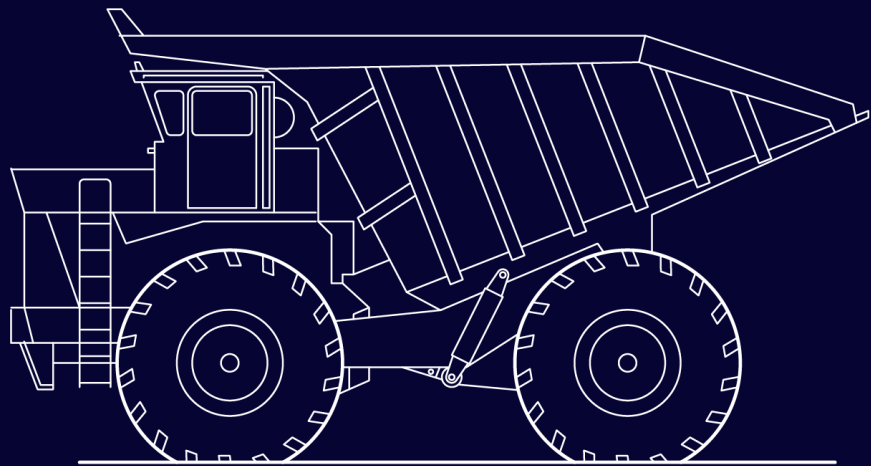

تأمین لاستیک

تعمیرات موتور لاستیک های از تاج های

تعمیرات لاستیک

تعمیرات لاستیک و ادی ال بد

پیما نیار

تعمیرات لاستیک

اددی ای ت امی ن ن ن ن ن ن ن

تعمیرات موتور لاستیک های از تاج های ...  
تعمیرات موتور لاستیک های از تاج های ...



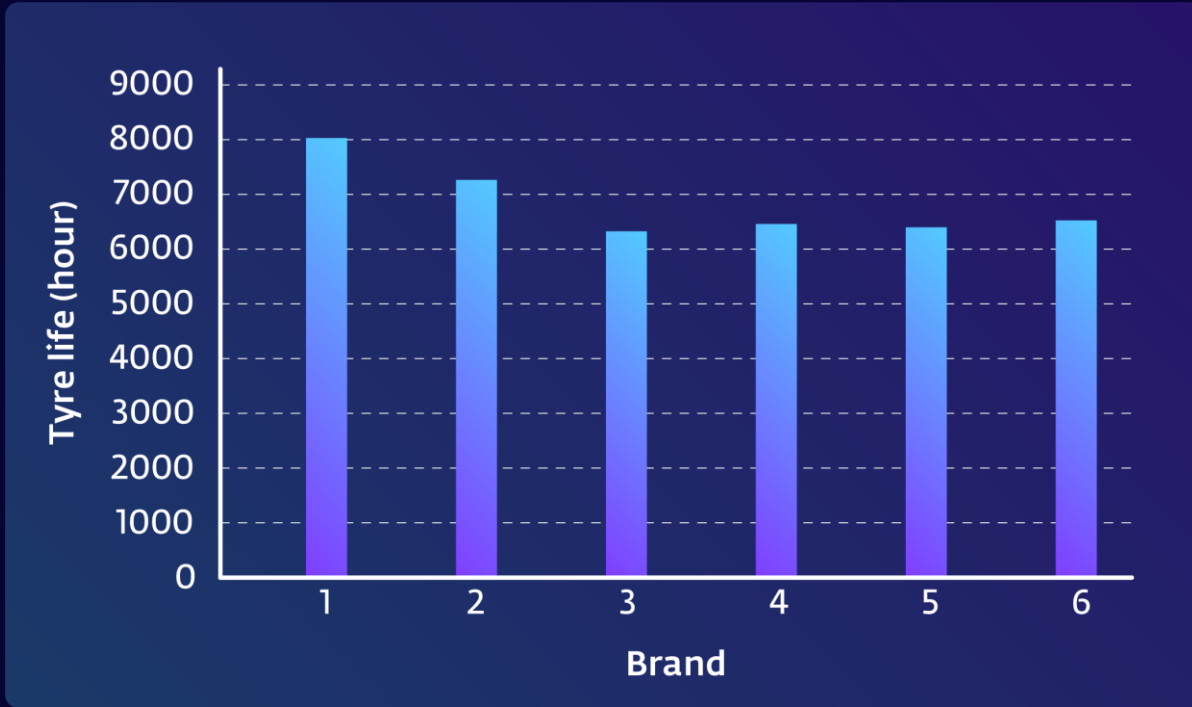

- [Pilot icon]
- [Pilot icon]
- [Pilot icon]
- [Pilot icon]
- [Pilot icon]
- [Pilot icon]





• می‌تواند به شما کمک کند تا بفهمید که آیا شما در حال حاضر در یک منطقه با درآمد پایین هستید یا نه.

این امر به شما کمک می‌کند تا بفهمید که آیا شما در حال حاضر در یک منطقه با درآمد پایین هستید یا نه.

• در حالی که درآمد شما در حال حاضر در یک منطقه با درآمد پایین است، این به شما کمک می‌کند تا بفهمید که آیا شما در حال حاضر در یک منطقه با درآمد پایین هستید یا نه.

این امر به شما کمک می‌کند تا بفهمید که آیا شما در حال حاضر در یک منطقه با درآمد پایین هستید یا نه.

• می‌تواند به شما کمک کند تا بفهمید که آیا شما در حال حاضر در یک منطقه با درآمد پایین هستید یا نه.

این امر به شما کمک می‌کند تا بفهمید که آیا شما در حال حاضر در یک منطقه با درآمد پایین هستید یا نه.

• می‌تواند به شما کمک کند تا بفهمید که آیا شما در حال حاضر در یک منطقه با درآمد پایین هستید یا نه.

این امر به شما کمک می‌کند تا بفهمید که آیا شما در حال حاضر در یک منطقه با درآمد پایین هستید یا نه.

این امر به شما کمک می‌کند تا بفهمید که آیا شما در حال حاضر در یک منطقه با درآمد پایین هستید یا نه.





۱۰۰٪ رضایت مشتریان

• ۱۰۰٪ رضایت مشتریان

• ۱۰۰٪ رضایت مشتریان

۱۰۰٪ رضایت مشتریان

• ۱۰۰٪ رضایت مشتریان

۱۰۰٪ رضایت مشتریان

۱۰۰٪ رضایت مشتریان

۱۰۰٪ رضایت مشتریان



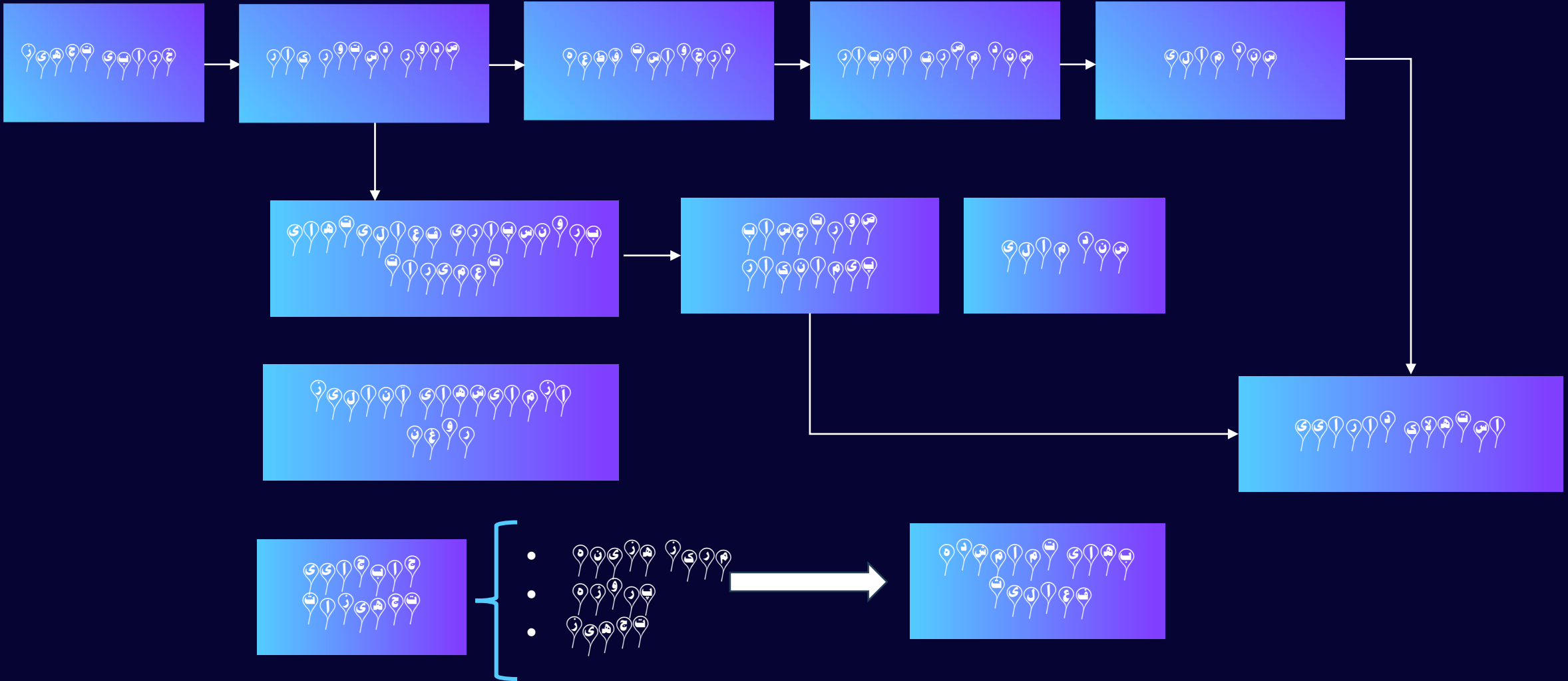

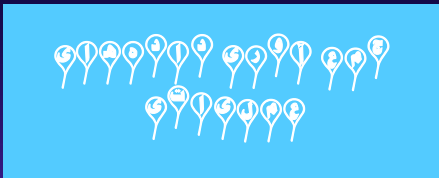
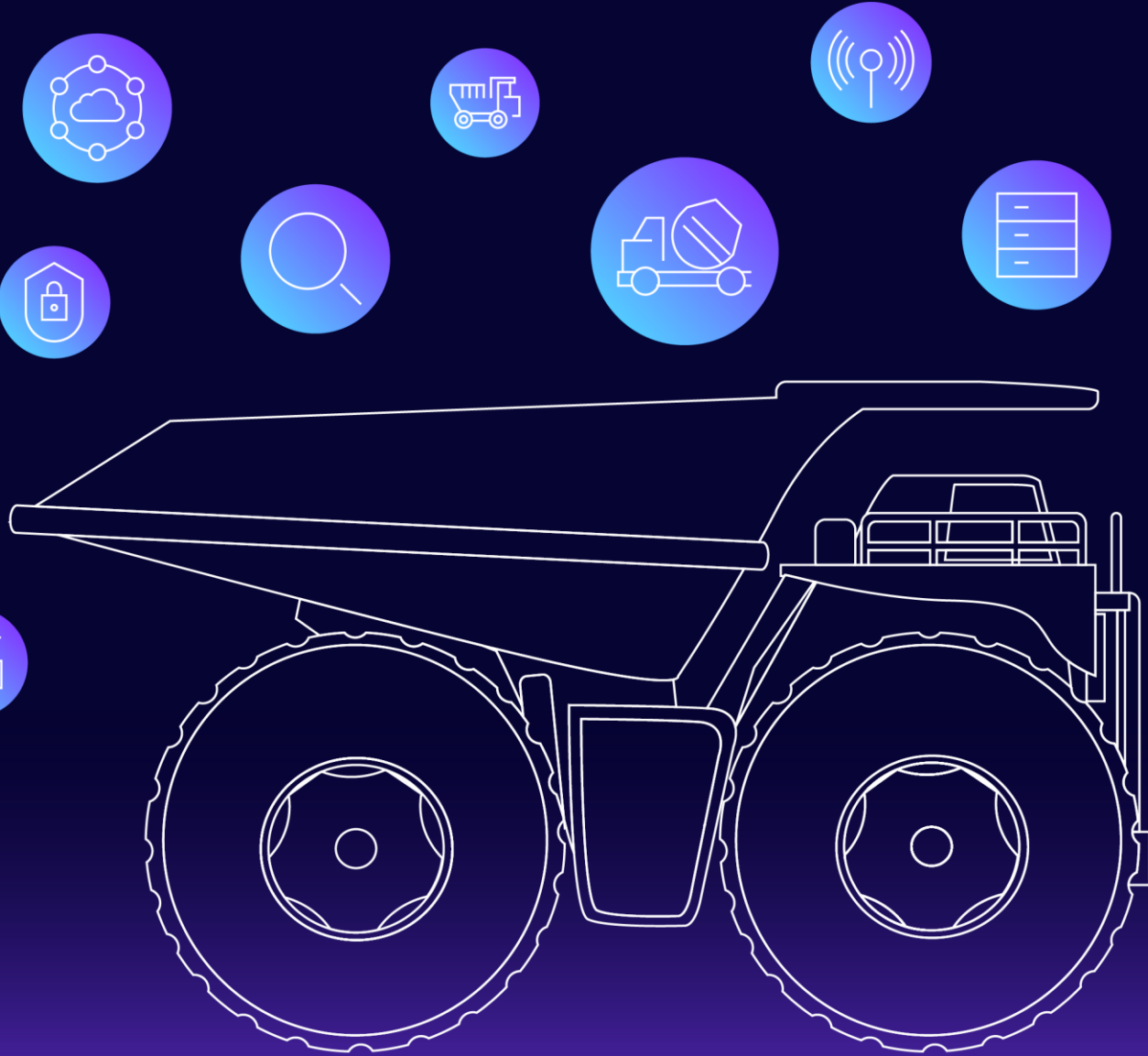



- اتصال به ماشین‌آلات
- ارسال اطلاعات کارکرد تجهیزات به ERP
- ثبت اتوماتیک اعلان خرابی در ERP
- هشدار در صورت خارج شدن مقدار از محدوده مجاز
- مشاهده مصرف سوخت، سرعت لحظه‌ای
- مشاهده دمای موتور، دما و فشار
- روغن موتور
- مشاهده داشبوردهای مدیریتی

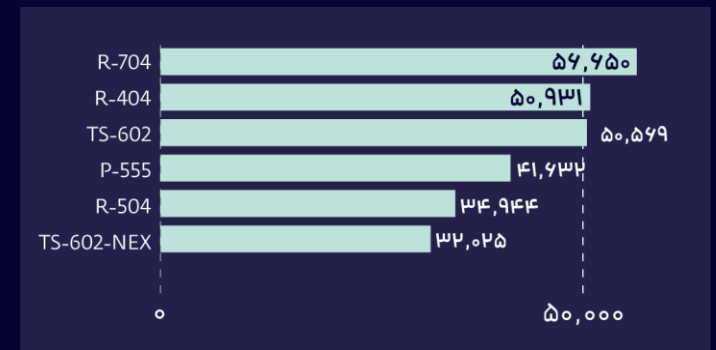
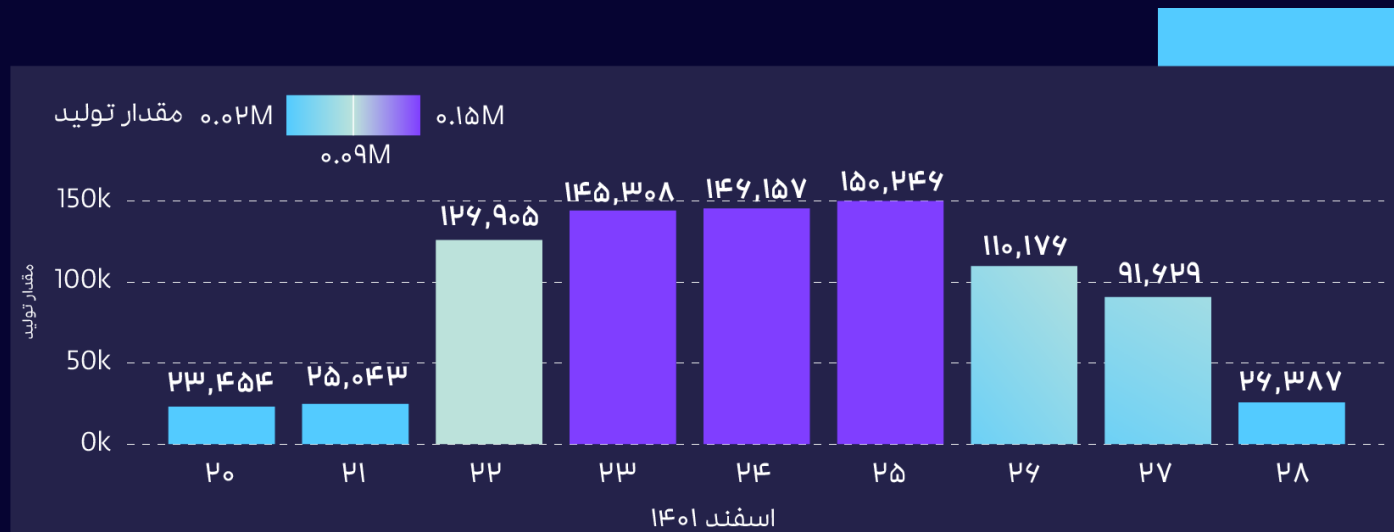
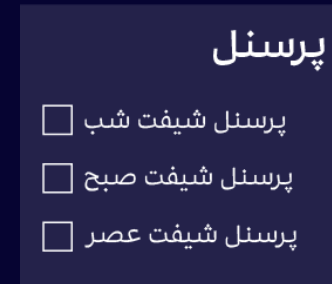
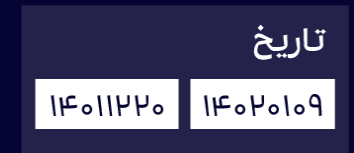
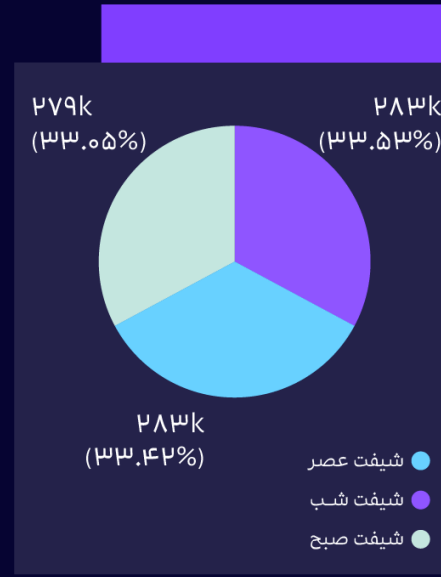
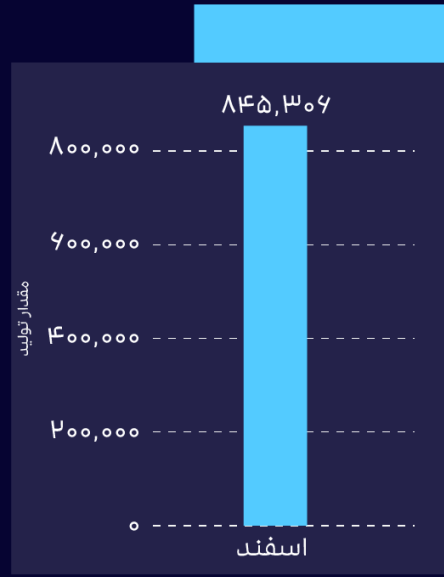
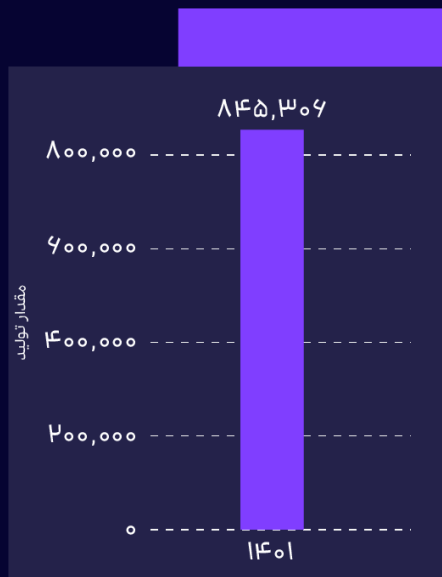

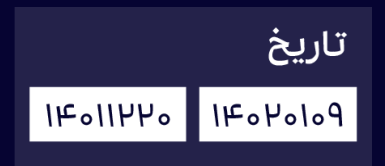
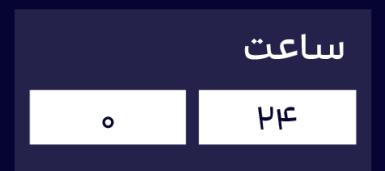
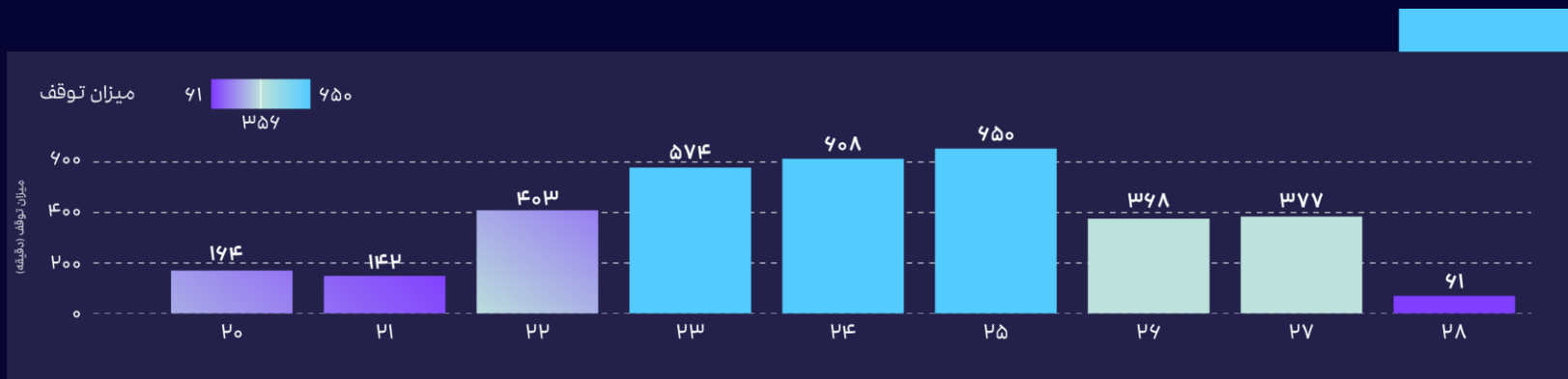
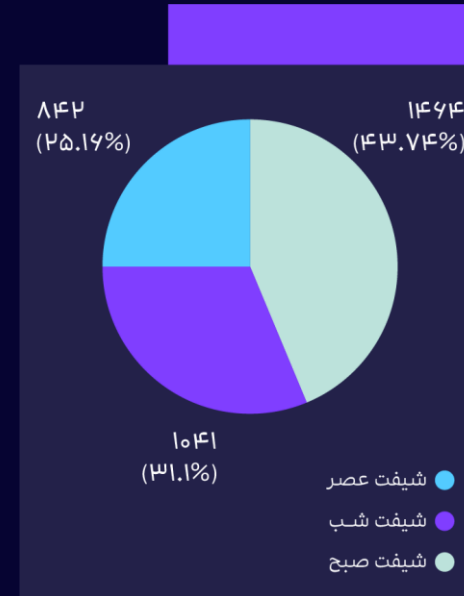
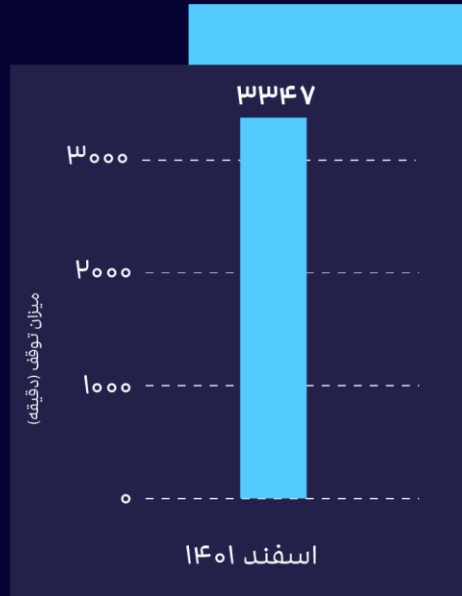
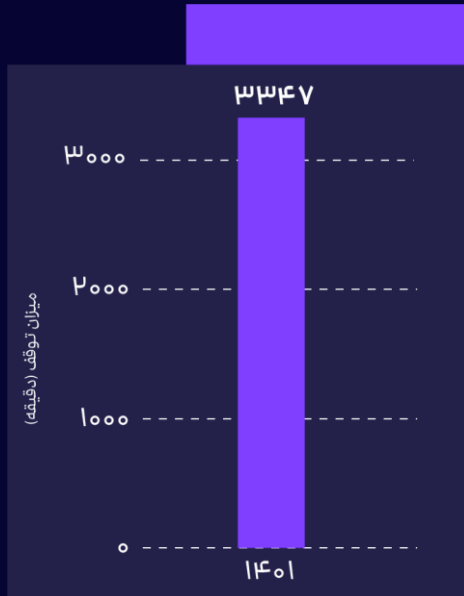





         •

  

   CBM •

   Predictive maintenance •





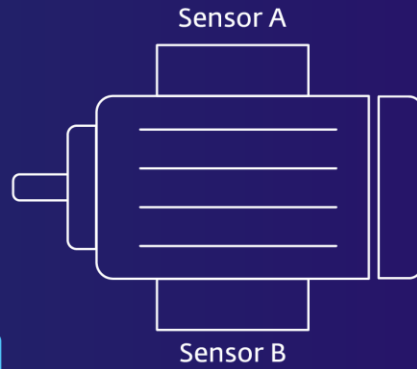
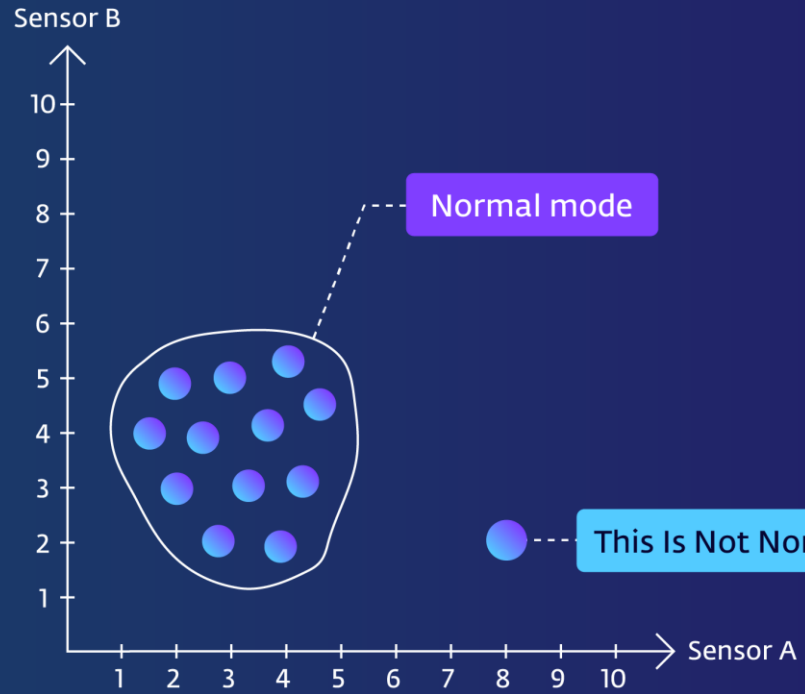

 ML AI •

 IOT •



همکاران  
سیستم